

New Humidifying System ระบบควบคุมความชื้นแนวใหม่

- 1. Humidity Control ควบคุมความชื้น
- 2. Reduce ESD. ลดไฟฟ้าสถิต
- 3. Dust Suppression ลดฝุ่น

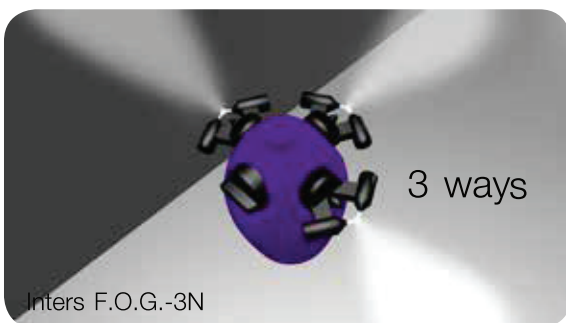

Dimensions

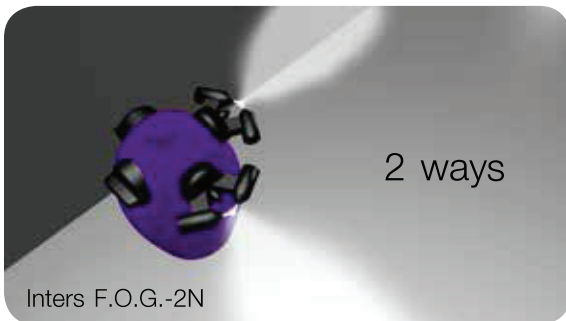
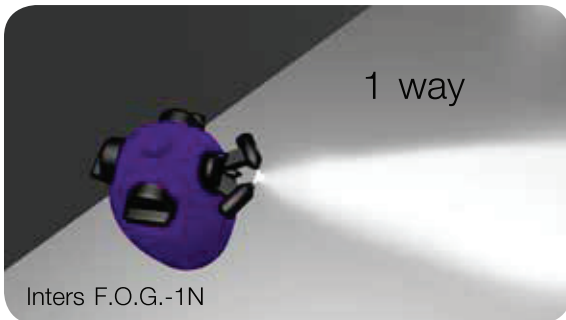
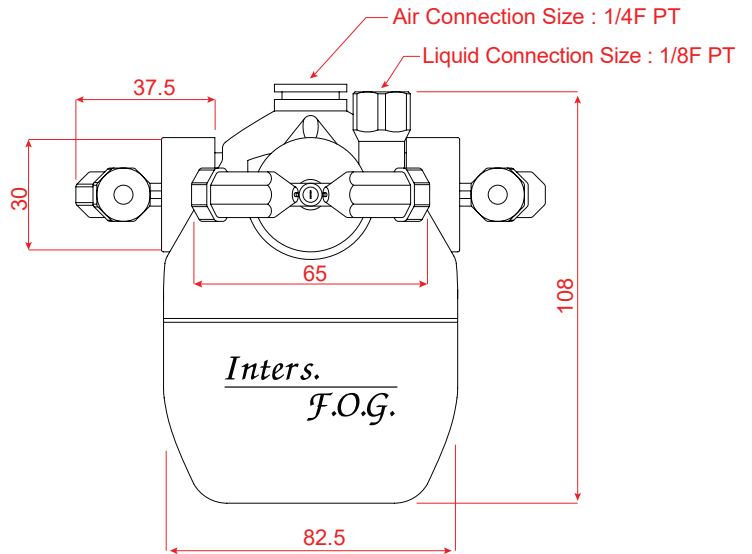

Features / คุณสมบัติเด่น

1. Small droplet size 7.5 μm Non-wet ด้วยเม็ดน้ำเล็กเพียง 7.5 ไมครอน ไม่ทำให้เปียก
2. Spray Volume 2.5 L/Hr ประหยัดปริมาณน้ำเพียง 2.5 ลิตร / ชั่วโมง
3. Spray coverage 4M. สเปรย์ครอบคลุมพื้นที่ได้มากถึง 4 เมตร
4. Light weight and easy installation
5. Designed for both automatic and manual usage
6. Free maintenance
7. ลด Defect ของ Product

Specifications

Model No.	Number of Nozzles	air pressure at 3 bar (44psi)	
		Spray Volume L/Hr	Air Consumption L/Min
Inters F.O.G.-1N	1	2.5	30
Inters F.O.G.-2N	2	5	60
Inters F.O.G.-3N	3	7.5	90
Inters F.O.G.-4N	4	10	120

Description Inters. F.O.G.

- Weight : 285.5g.
- Material : Zytel® 30G Nylon Resin (Dupont Performance Polymers)
- Nozzle Tip : Stainless steel

Support Kits

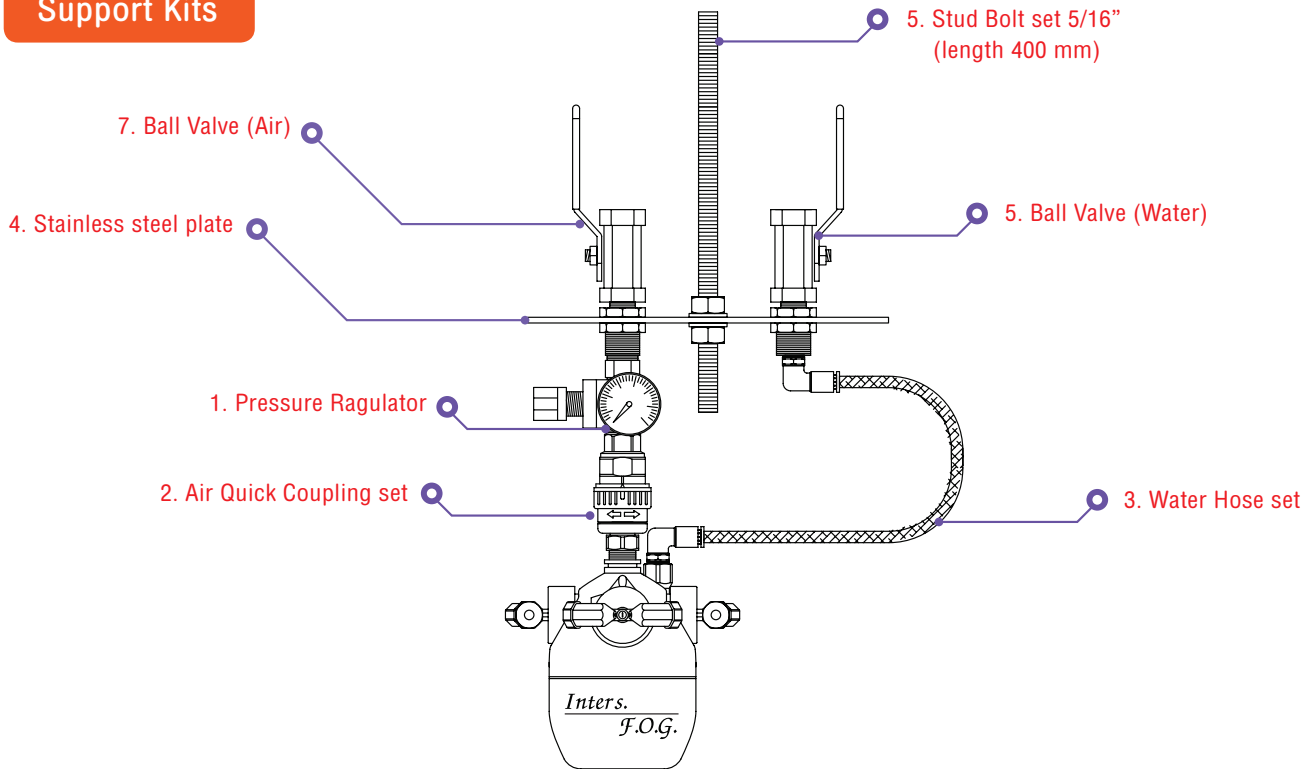

Design & Consult Inters. F.O.G. Technology



| Increase Humidity | Cooling | Dust Suppression | Fog Atmosphere | Curing |

No electricity needed, Operates solely by air pressure set Inters. F.O.G. - 1N-PT

ตัวเครื่องไม่ต้องใช้ไฟฟ้า เพียงต่อเข้ากับลม ก็สามารถใช้งานได้ทันที



Portable set Feature

1. Easy and Convenience to add humidity no need for piping, easily setup close to machine
2. Reduce ESD and dust scattered around for a better quality of
3. Suitable for electronic parts, Painting, Autoparts, Plastic parts applicable
4. Reduce defects in production

standard set

1. Inters. F.O.G. - IN
2. Stand with wheels
3. Telescopic pole
4. Pressure tank
5. Pressure Regulator with gauge
6. Mounting Unit
7. Safety Valve

Standard Dimensions

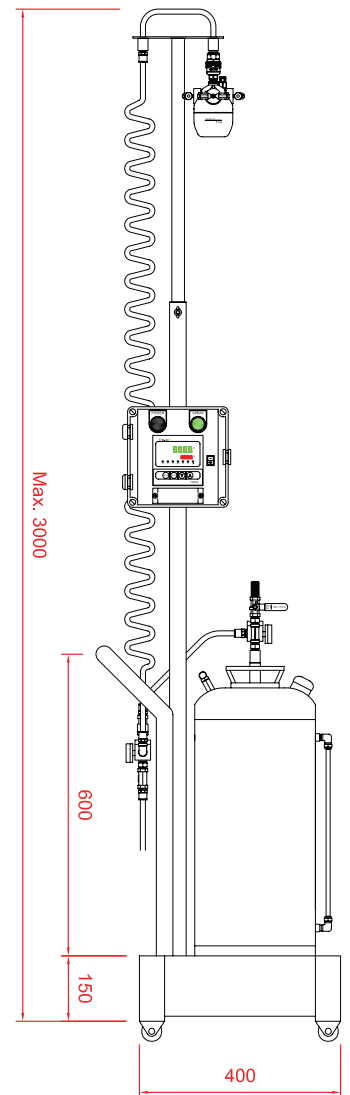

Pressure Tank Specification

Capacity	: 18 Litres
Material	: Stainless steel 304*
Pressure	: 0.7MPa
Weight	: 6 kg.

* Material is available upon request



Humidity Controller : HCT-163-1



Sensor : HSR-163-2

Inters. F.O.G. System Features

- Digital display of humidity figure and humidity target
- Compact size to fit and place
- Measurement accuracy : $\pm 2\%$
- Supply voltage : 220 - 240 V
- Range of operation 10-90% RH (0-50C°)

Applications



Precise Nozzle Solution

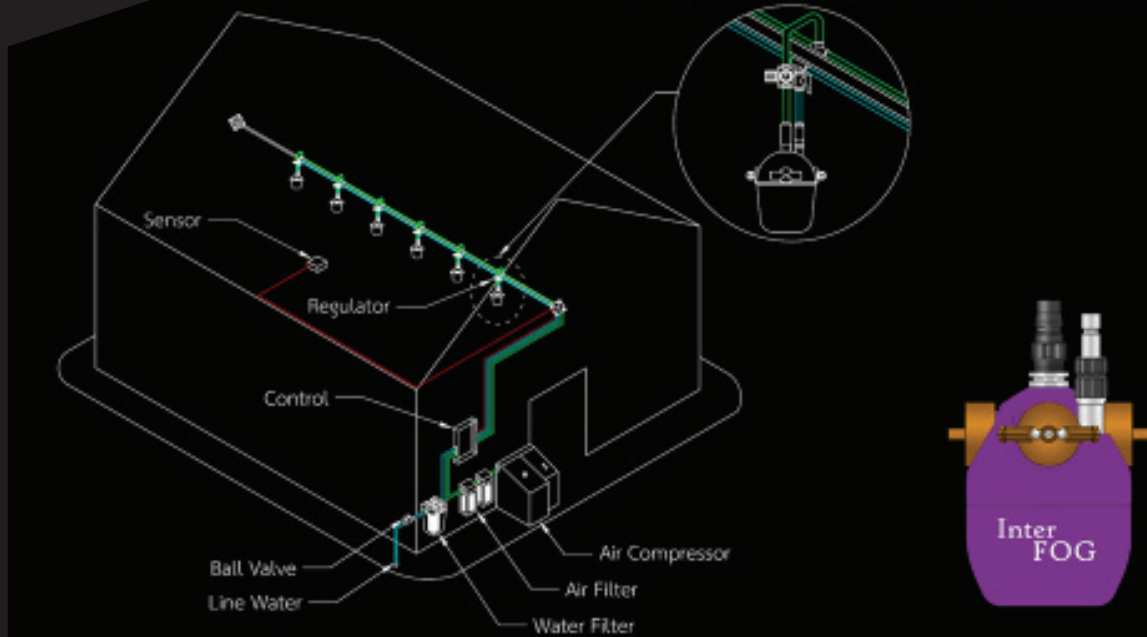

Service and installation

