

Self-rotating

Tank Cleaning Nozzles

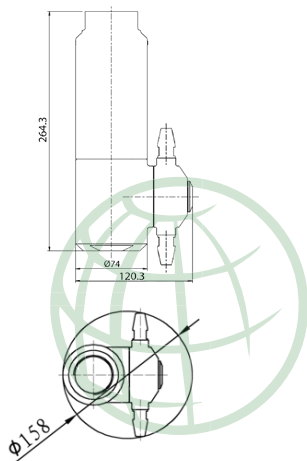

Dimension



Feature

The rotary jet head provides a powerful and thorough 360-degree cleaning pattern. The standard machine configuration uses two nozzles to blast the tank walls and rinse all surfaces. In operation, the unit has to run for the cycle time between on type 8 and 12 min depending on type and pressure. This ensures full cleaning. For extremely difficult applications the cleaning time might have to be extend.

Performance data

Material	:	316L SS
Spray angle	:	360°
Max. cleaning diameter	:	Ø 20 m
Tank openings	:	160 mm
Operating Pressure	:	2-30 bar
Max. operating temperature	:	95°C
Connection	:	1 1/2"

Application

- Cleaning all Industry
- Cosmetic Industry
- Food & Beverage Industry
- Chemical Industry
- Pharmaceutical Industry

Special Feature

- Driven and lubricated by the cleaning fluid
- Very high cleaning performance already at low pressure
- Robust, low-maintenance.
- Using dynamic seal at leakage point to reduce leakage and save cleaning fluid. While producing greater impact on the water flow.
- The nozzle have a unique steady flow design which can make the jet be more concentrated, greater impact.

Programmed Rotation Machines

The cleaning fluid drives via the turbine an internal gear reducer that keeps the sprayer turning in two planes. In the course of spraying cycle, the jets sweep the entire inside surface of the tank according to the preprogrammed, model-specific pattern. This takes a certain amount of time, This models generate the highest jet pressures (= force of impact)

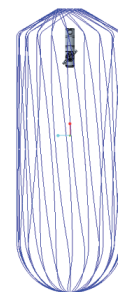
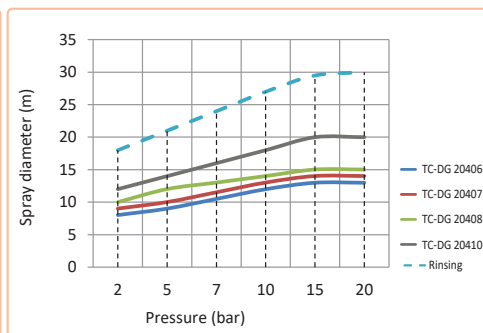
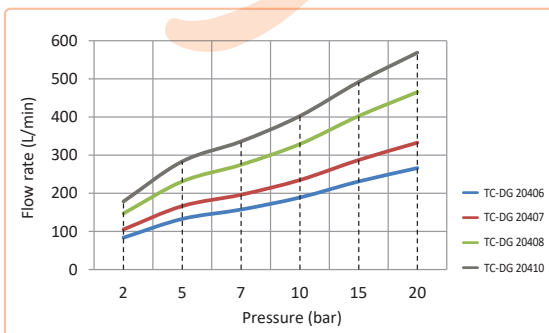

First circle

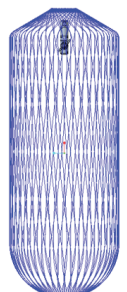

Full pattern

How to order (Example)

TC-DG 20410

Model

360°

Angle

316LSS

Material

1 1/2" BSPP

Connection